

Panasonic

Energy Recovery Ventilator

Convenient | Refresh | Energy Efficient



IMPORTANCE OF INDOOR AIR QUALITY

Buildings nowadays mostly are tightly built with aluminum casing windows and rubber lining door to retain energy efficiency and limit heating or cooling loss. However, it comes at the cost of poor indoor air quality. In order to provide a healthy living environment to you, ventilation plays an essential role.

WHY INDOOR AIR QUALITY IS IMPORTANT?

You can't see it, but you take a lot into your body – AIR

Air quality in a house is an important factor for your health and comfort. In general, windows are not opened in airtight house due to using of air conditioning.

It is difficult to fulfill air exchange in a modern house, as a result, the stale indoor air becomes polluted easily.

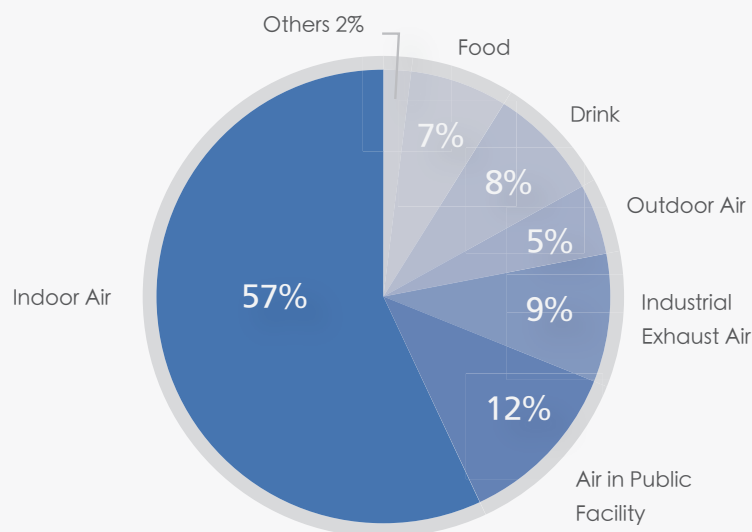

Source: Murakami Shuzo, "Indoor Environments and Air Pollutants"

Besides "Sick House Syndrome", insufficient ventilation also affects human's health and aging of building

- Yellow stain on wall caused by tobacco smoking
- Allergic illnesses induced with mold and mite that are caused by moisture
- Discomfort due to smells from toilet and cooking
- Lowering of concentration due to shortage of oxygen
- Building deterioration resulting from condensation and mold

AIR PROBLEMS IN HOME

Home Airtightness

Homes designed and built in recent years are more airtight and energy efficient than in the past. To obtain an airtight design, house wraps, newly designed windows and doors, sealing caulks and other insulating materials are used to create a seal for optimum energy efficiency. It results the cost saving to heat and air-condition at home, but pollutants retained in airtight buildings can be hazardous to our health and can jeopardize structural integrity.

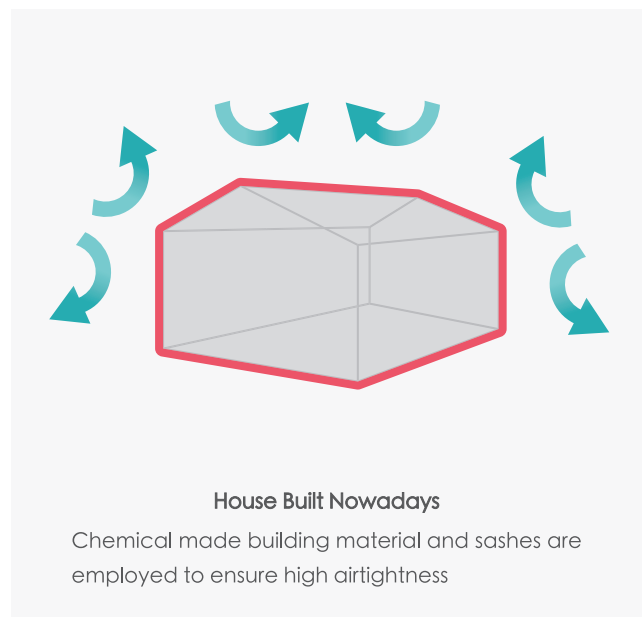
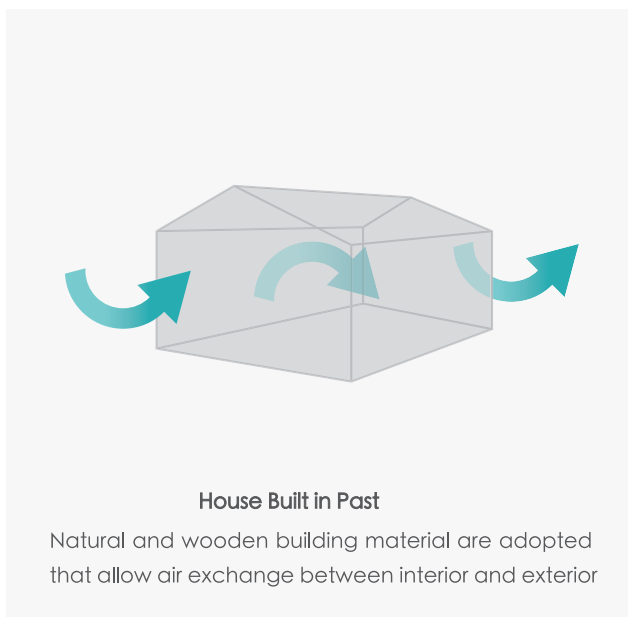

Issues Raised with Home Airtightness?

Highly airtight house restricts air ingress from outside that can closely retain the expected indoor temperature for energy saving. However, airtightness also brings out the problem of indoor air quality (IAQ) which may be a cause of sick house syndrome.

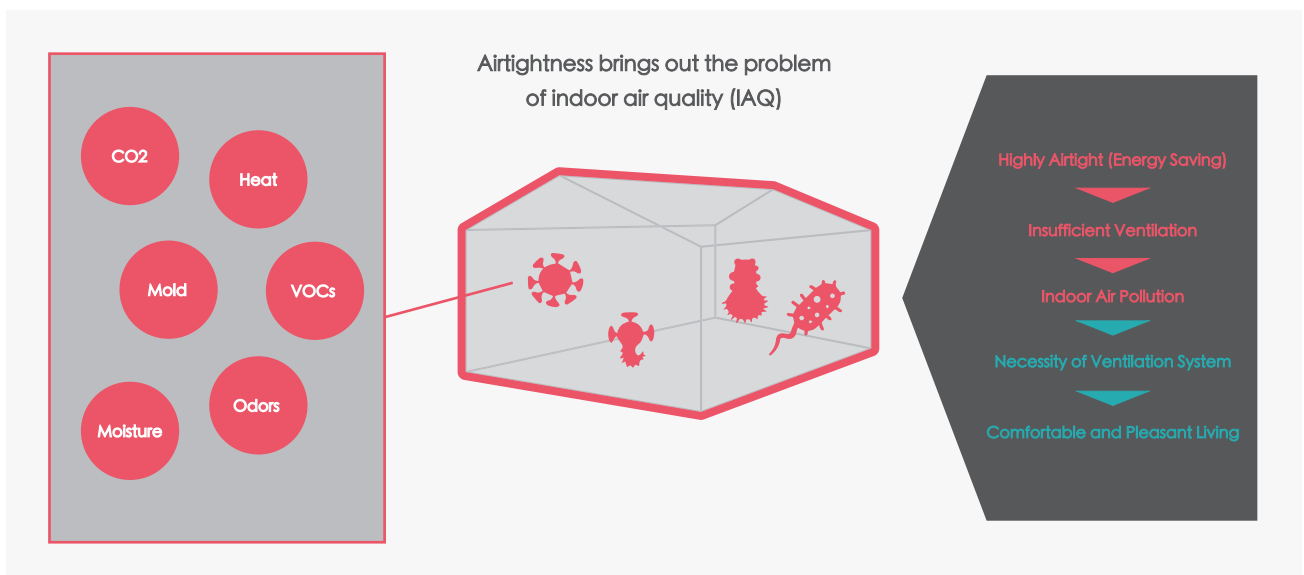

AIR QUALITY

CONVENIENT

WHY INDOOR AIR QUALITY IS IMPORTANT?

With 24-hour continuous ventilation, fresh air will circulate around the whole house. As ventilation with energy recovery ventilator, energy loss of air conditioning (including sensible heat and latent heat) is minimized. This provides a highly efficient, energy saving ventilated environment.

PANASONIC INNOVATIVE
SLIM DESIGN



Enjoy Double Comfort with Interlocking Air Conditioning

The newly developed energy recovery ventilator can interlock air conditioning. It allows you to enjoy both fresh air and comfortable temperature.

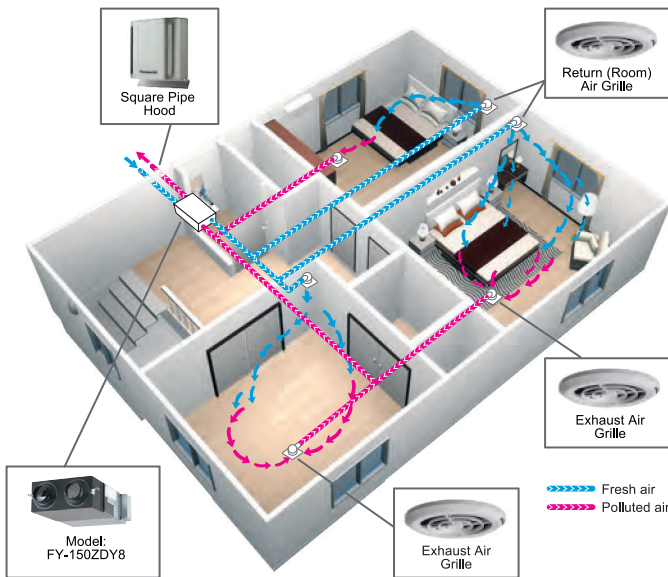

Inside of Heat Exchange Core (diagram)

SUMMER

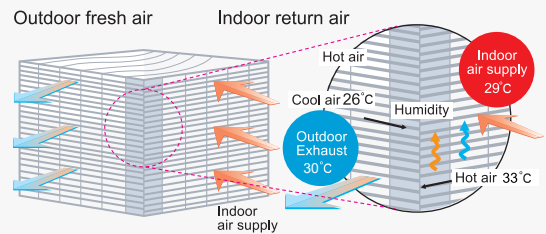

Principle of Heat Exchange

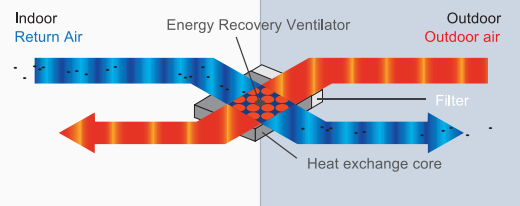

Slim Body Shape and Improved Installability

Counter-flow heat-exchange element used for reduced noise and more compact and slim body shape.

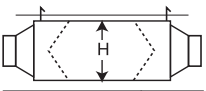

Model No.	H
FY-150ZDY8	270
FY-250ZDY8	270
FY-350ZDY8	317
FY-500ZDY8	317

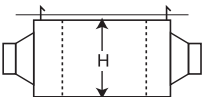

Model No.	H
FY-650ZDY8	388
FY-800ZDY8	388
FY-01KZDY8	388

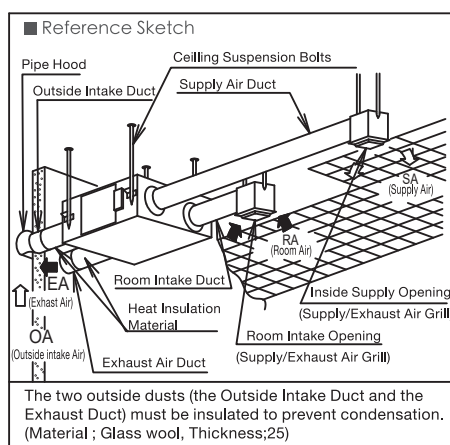

Model No.	Duct Size (Nominal Diameter)
FY-150ZDY8	Ø100
FY-250ZDY8 / FY-350ZDY8	Ø150
FY-500ZDY8 FY-650ZDY8	Ø200
FY-800ZDY8 / FY-01KZDY8	Ø250

Reverse-Mountable Direct Air Supply/Exhaust System

- Adoption of straight air supply/exhaust system Duct design is simplified because the air supply/exhaust ducts are straight.
- Since each unit can be mounted in reverse position, only one inspection hole is needed for two units. Two units can share one inspection hole so ductwork is easier and more flexible.

Can be installed in reverse position

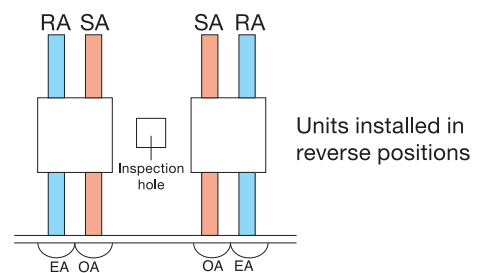

REFRESH

WHOLE HOUSE FILLED WITH FRESH AIR

With 24-hour continuous ventilation, stale air is exhausted while fresh air is enters into the house. Circulation of fresh air throughout the whole house is maintained.

Structure Diagram



- **Pre Filter** Filter outdoor large dust particles and insects
- Recommended to change filter every year and clean every month

Pre Filter

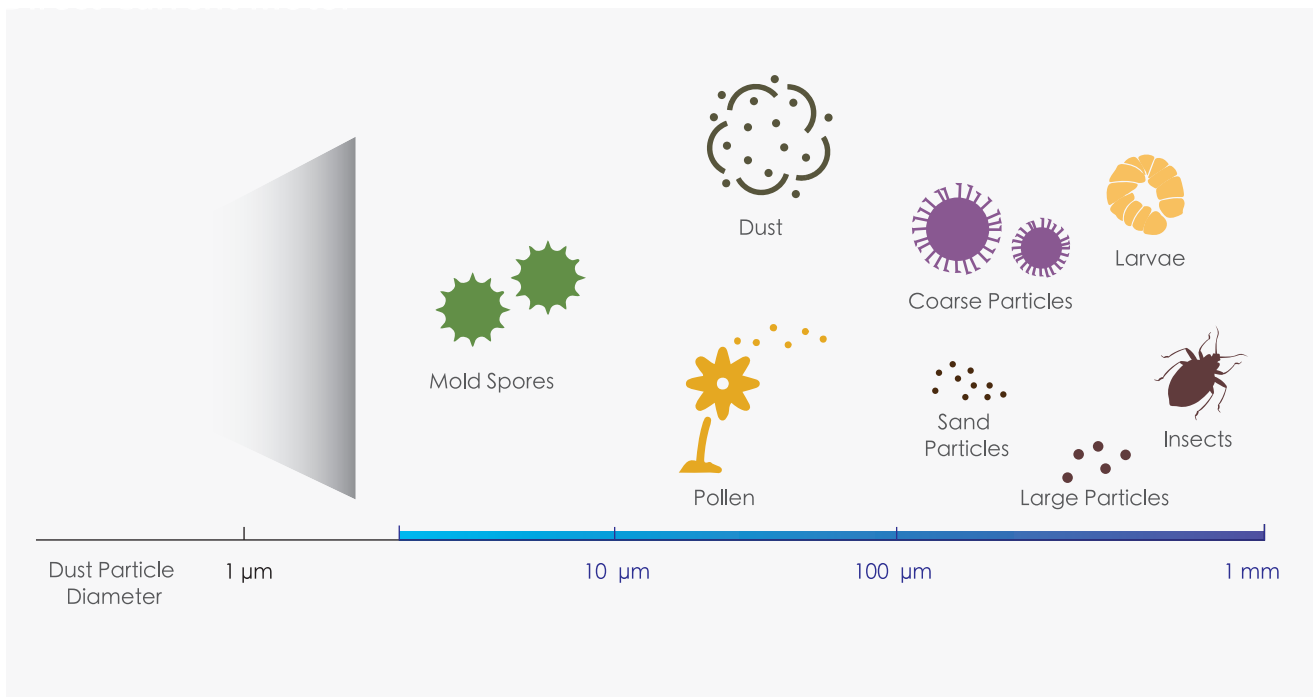

Bypass Ventilation for Speedy Exhaust of Polluted Air

Diversion damper is equipped for Bypass Ventilation. Return (room) airflow (RA) is greater than supply airflow (SA) allowing speedy exhaust of indoor polluted air.

By using bypass ventilation during season change, it will be more comfortable and energy saving.

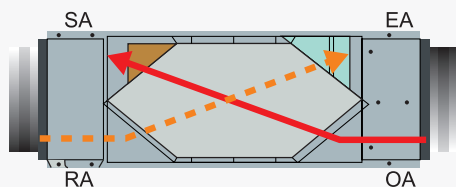

[Heat Exchange Mode]

* In heat exchange mode, hot outdoor air is precool before supplied into rooms. Thus, saving energy at the same time providing fresh air.

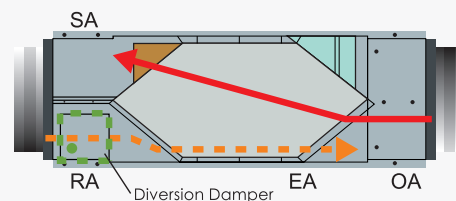

[Normal Ventilation Mode]

- Bypass ventilation
- * In case outdoor air is highly polluted, it is not recommended to use bypass ventilation. It may cause negative pressure that polluted outdoor air may ingress into the houses through the gaps at the doors and windows.

COST EFFICIENT

CONSIDERATE DESIGN FOR EXTRA SAVING

Merit of Energy Recovery Ventilation

Highly efficient energy recovery reduce energy loss during ventilation, that achieve energy saving (Example: FY-150ZDY8)

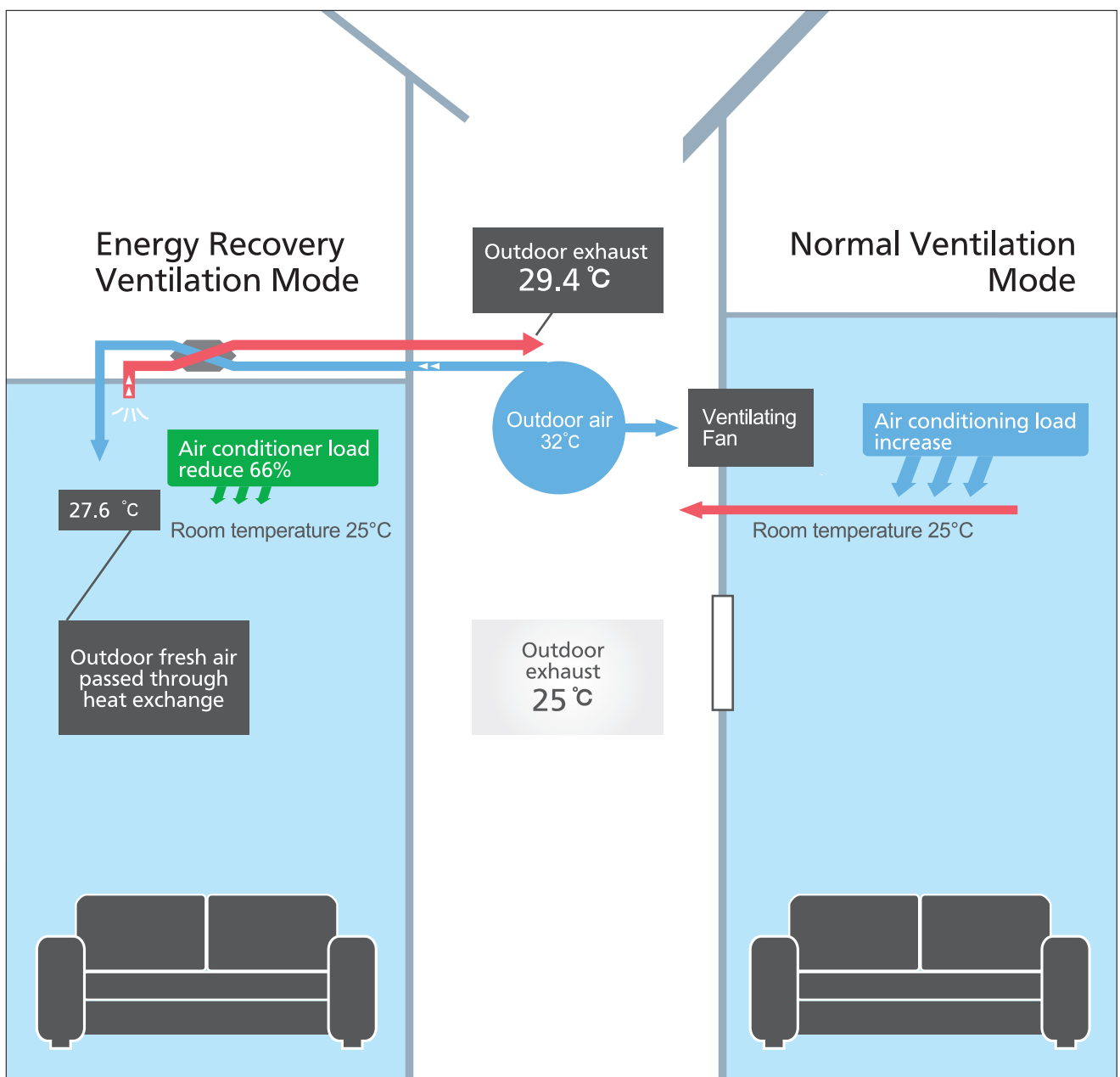

Summer

Utilize energy of indoor return cool air to cool down outdoor air before intake to indoor, indoor cool loss is reduced

Long Term Cost Comparison

Long term cost comparison for Panasonic ventilation fan and energy recovery ventilator

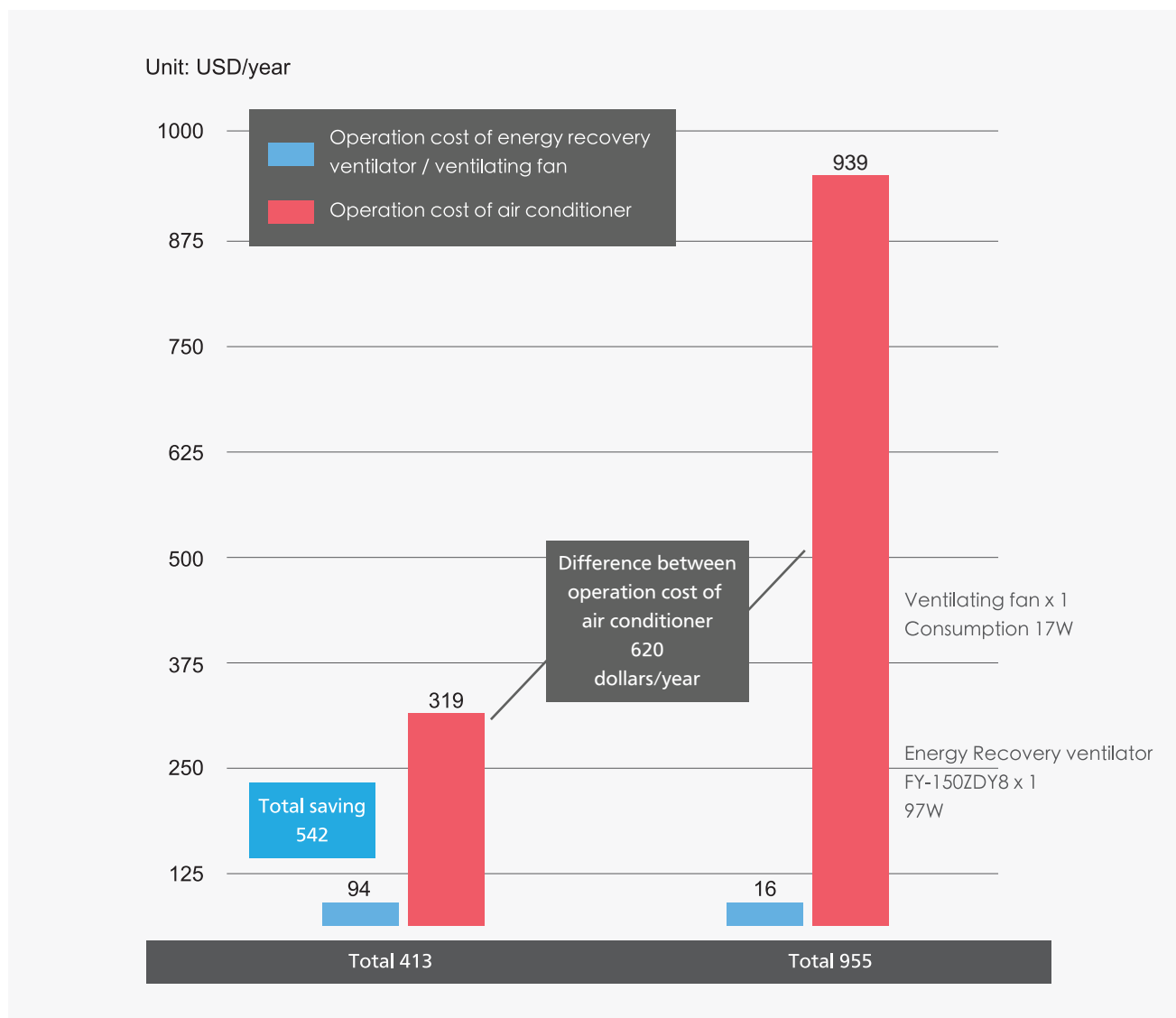

Based on the following condition

[Test condition]

Location: Indonesia

Indoor : Cooling 25° C (RH50%)

Outdoor : 32° C (RH72%)

Ventilation air volume: 100m² x 3m x 0.5 times/h = 150m³/h

Operation Time

Air Conditioner: 12 hrs/day x 365 days = 4380 hrs

Ventilation: 24 hrs/day x 365 days = 8760 hrs

Electricity charge: USD0.11/KW.h

Since energy recovery ventilator can reduce ventilation load, cooling and heating load of air conditioner are decreased subsequently. Thus the initial equipment cost for air conditioner can be possibly reduced.

Remark: Reading was carried out in a controlled environment.
Actual result might vary.

ENERGY RECOVERY VENTILATORS

FY-150ZDY8



Features

- Counter-flow heat-exchange element used for reduced noise and more compact and slim body shape.
- All maintenance can be performed through a single inspection hole.
- Straight air supply/exhaust system used for easier installation.
- Each unit can be mounted in reverse position.
- Equipped with a Extra-High setting.
- Can incorporate a medium-performance filter (optional, installed at site).

Performance

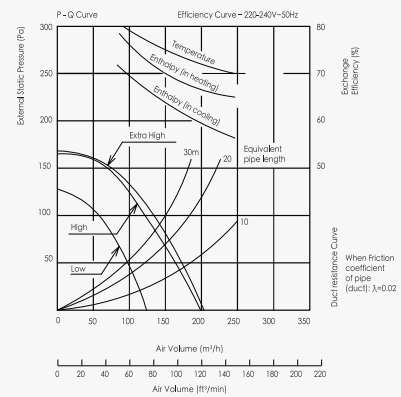

Dimensions & Parts Name

Unit: mm

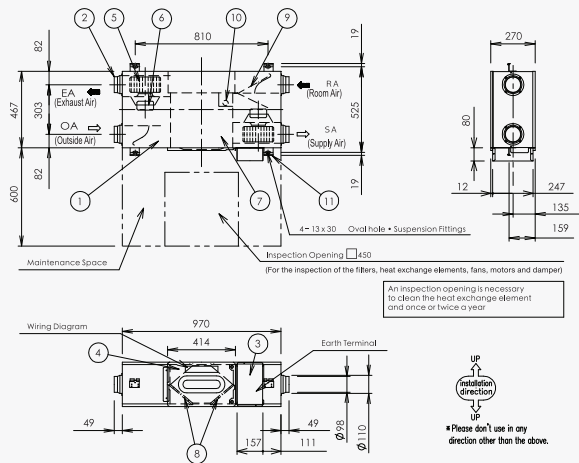

No.	Parts Name	Qty.
1	Frame	1
2	Adapter	4
3	Electrical Equipment Box	1
4	Inspection Cover	1
5	Fan	2
6	Motor	2
7	Heat Exchange Element	1
8	Filter	2
9	Damper	1
10	Damper Motor	1
11	Ceiling Suspension Fixture	4

Remarks:

- Duct Size (Nominal Diameter): Ø100
- The dimensions do not include the thickness of the insulation material in the unit

Specification

Power Source	Notch	Frequency	Ventilation Mode	Input [W]	Current [A]	Air Volume [m³/h]	External Static Pressure [Pa]	Temperature Exchange Efficiency (%)	Enthalpy Exchange Efficiency (%)		Noise [dB]	Product Weight [kg]
									Cooling	Heating		
220 - 240V ~	Extra High	50	Heat Exchange Ventilation	97-114	0.44-0.48	150	80	75	63	70	28.5-29.0	25
			Normal Ventilation	97-114	0.44-0.48	150	80	-	-	-	28.5-29.0	
	High	50	Heat Exchange Ventilation	92-107	0.42-0.45	150	70	75	63	70	28.0-29.0	
			Normal Ventilation	92-107	0.42-0.45	150	70	-	-	-	28.0-29.0	
	Low	50	Heat Exchange Ventilation	69-77	0.31-0.32	120	25	77	66	73	19.5-21.5	
			Normal Ventilation	69-77	0.31-0.32	120	25	-	-	-	19.5-21.5	

* This noise of the product is the value which was measured at the acoustic room. Actually, in the established condition, that undergo influence by the echoing of the room and so that become bigger than the display numerical value. The input, current and exchange efficiency are values at the time of mentioned air volume. The noise level shall be measured 1.5m below the center of the unit. The temperature exchange efficiency averages that of when cooling and when heating.

FY-250ZDY8



Features

- Counter-flow heat-exchange element used for reduced noise and more compact and slim body shape.
- All maintenance can be performed through a single inspection hole.
- Straight air supply/exhaust system used for easier installation.
- Each unit can be mounted in reverse position.
- Equipped with a Extra-High setting.
- Can incorporate a medium-performance filter (optional, installed at site).

Performance

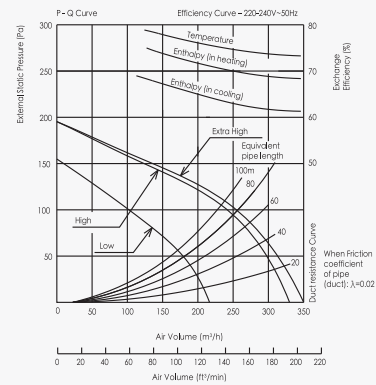

Dimensions & Parts Name

Unit: mm

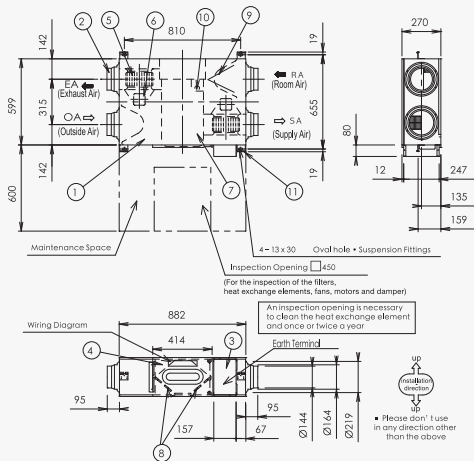

No.	Parts Name	Qty.
1	Frame	1
2	Adapter	4
3	Electrical Equipment Box	1
4	Inspection Cover	1
5	Fan	2
6	Motor	2
7	Heat Exchange Element	1
8	Filter	2
9	Damper	1
10	Damper Motor	1
11	Ceiling Suspension Fixture	4

Remarks:
 ■ Duct Size (Nominal Diameter): Ø150
 ■ The dimensions do not include the thickness of the insulation material in the unit

Specification

Power Source	Notch	Frequency	Ventilation Mode	Input [W]	Current [A]	Air Volume [m³/h]	External Static Pressure [Pa]	Temperature Exchange Efficiency (%)	Enthalpy Exchange Efficiency (%)		Noise [dB]	Product Weight [kg]
									Cooling	Heating		
220 - 240V	Extra High	50	Heat Exchange Ventilation	112-128	0.51-0.53	250	105	75	63	70	30.0-31.5	29
			Normal Ventilation	112-128	0.51-0.53	250	105	-	-	-	30.0-31.5	
	High	50	Heat Exchange Ventilation	108-123	0.49-0.51	250	95	75	63	70	29.5-30.5	
			Normal Ventilation	108-123	0.49-0.51	250	95	-	-	-	29.5-30.5	
	Low	50	Heat Exchange Ventilation	87-96	0.40-0.41	190	45	77	65	72	23.5-26.5	
			Normal Ventilation	87-96	0.40-0.41	190	45	-	-	-	23.5-26.5	

* This noise of the product is the value which was measured at the acoustic room. Actually, in the established condition, that undergo influence by the echoing of the room and so that become bigger than the display numerical value. The input, current and exchange efficiency are values at the time of mentioned air volume. The noise level shall be measured 1.5m below the center of the unit. The temperature exchange efficiency averages that of when cooling and when heating.

ENERGY RECOVERY VENTILATORS

FY-350ZDY8



Features

- Counter-flow heat-exchange element used for reduced noise and more compact and slim body shape.
- All maintenance can be performed through a single inspection hole.
- Straight air supply/exhaust system used for easier installation.
- Each unit can be mounted in reverse position.
- Equipped with a Extra-High setting.
- Can incorporate a medium-performance filter (optional, installed at site).

Performance

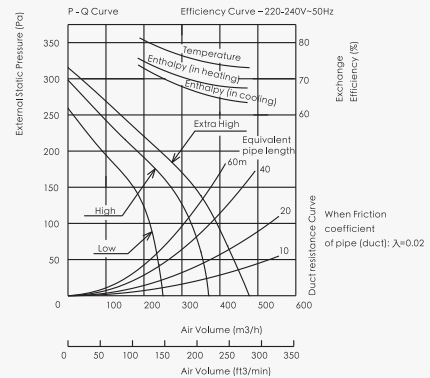

Dimensions & Parts Name

Unit: mm

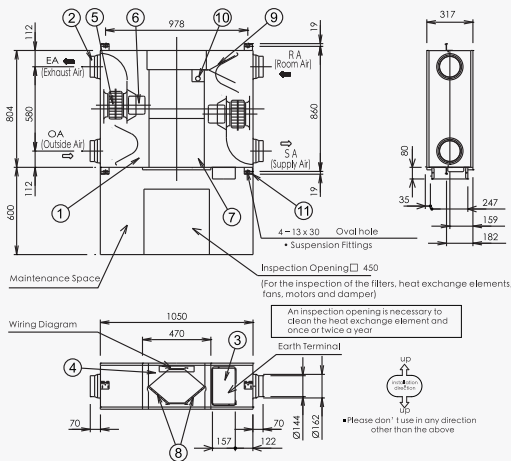

No.	Parts Name	Qty.
1	Frame	1
2	Adapter	4
3	Electrical Equipment Box	1
4	Inspection Cover	1
5	Fan	2
6	Motor	2
7	Heat Exchange Element	2
8	Filter	2
9	Damper	1
10	Damper Motor	1
11	Ceiling Suspension Fixture	4

Remarks:

- Duct Size (Nominal Diameter): $\varnothing 150$
- The dimensions do not include the thickness of the insulation material in the unit

Specification

Power Source	Notch	Frequency	Ventilation Mode	Input [W]	Current [A]	Air Volume [m³/h]	External Static Pressure [Pa]	Temperature Exchange Efficiency (%)	Enthalpy Exchange Efficiency (%)		Noise [dB]	Product Weight [kg]
									Cooling	Heating		
220 - 240V	Extra High	50	Heat Exchange Ventilation	182-190	0.79-0.83	350	140	75	62	69	32.5-33.0	49
			Normal Ventilation	182-190	0.79-0.83	350	140	-	-	-	32.5-33.0	
	High	50	Heat Exchange Ventilation	178-185	0.77-0.81	350	60	75	62	69	30.5-31.0	
			Normal Ventilation	178-185	0.77-0.81	350	60	-	-	-	30.5-31.0	
	Low	50	Heat Exchange Ventilation	168-175	0.70-0.79	240	45	78	71	73	22.5-25.5	
			Normal Ventilation	168-175	0.70-0.79	240	45	-	-	-	22.5-25.5	

* This noise of the product is the value which was measured at the acoustic room. Actually, in the established condition, that undergo influence by the echoing of the room and so that become bigger than the display numerical value. The input, current and exchange efficiency are values at the time of mentioned air volume. The noise level shall be measured 1.5m below the center of the unit. The temperature exchange efficiency averages that of when cooling and when heating.

FY-500ZDY8



Features

- Counter-flow heat-exchange element used for reduced noise and more compact and slim body shape.
- All maintenance can be performed through a single inspection hole.
- Straight air supply/exhaust system used for easier installation.
- Each unit can be mounted in reverse position.
- Equipped with a Extra-High setting.
- Can incorporate a medium-performance filter (optional, installed at site).

Performance

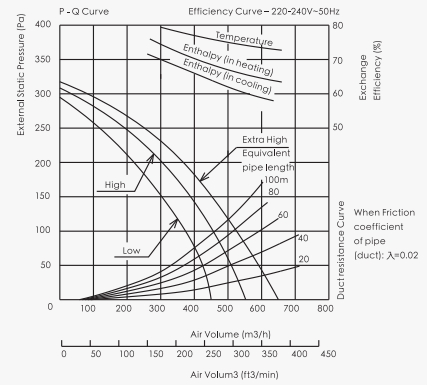

Dimensions & Parts Name

Unit: mm

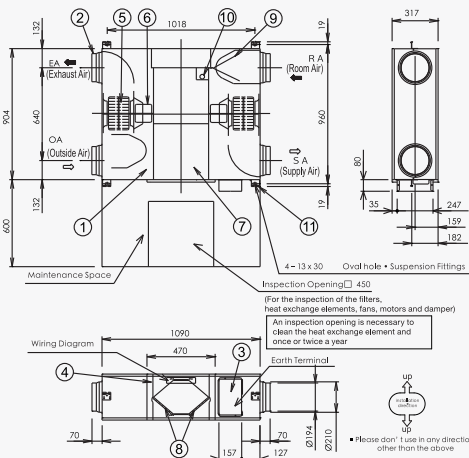

No.	Parts Name	Qty.
1	Frame	1
2	Adapter	4
3	Electrical Equipment Box	1
4	Inspection Cover	1
5	Fan	2
6	Motor	2
7	Heat Exchange Element	2
8	Filter	2
9	Damper	1
10	Damper Motor	1
11	Ceiling Suspension Fixture	4

Remarks:
 ■ Duct Size (Nominal Diameter): Ø200
 ■ The dimensions do not include the thickness of the insulation material in the unit

Specification

Power Source	Notch	Frequency	Ventilation Mode	Input [W]	Current [A]	Air Volume [m³/h]	External Static Pressure [Pa]	Temperature Exchange Efficiency (%)	Enthalpy Exchange Efficiency (%)		Noise [dB]	Product Weight [kg]
									Cooling	Heating		
220 - 240V	Extra High	50	Heat Exchange Ventilation	263-289	1.20-1.21	500	120	75	62	67	36.5-37.5	57
			Normal Ventilation	263-289	1.20-1.21	500	120	-	-	-	37.5-38.5	
	High	50	Heat Exchange Ventilation	204-225	0.93-0.94	500	60	75	62	67	34.5-35.5	
			Normal Ventilation	204-225	0.93-0.94	500	60	-	-	-	37.0-38.0	
	Low	50	Heat Exchange Ventilation	165-185	0.75-0.77	440	35	76	64	69	31.0-32.5	
			Normal Ventilation	165-185	0.75-0.77	440	35	-	-	-	31.0-32.5	

* This noise of the product is the value which was measured at the acoustic room. Actually, in the established condition, that undergo influence by the echoing of the room and so that become bigger than the display numerical value. The input, current and exchange efficiency are values at the time of mentioned air volume. The noise level shall be measured 1.5m below the center of the unit. The temperature exchange efficiency averages that of when cooling and when heating.

ENERGY RECOVERY VENTILATORS

FY-650ZDY8



Features

- Counter-flow heat-exchange element used for reduced noise and more compact and slim body shape.
- All maintenance can be performed through a single inspection hole.
- Straight air supply/exhaust system used for easier installation.
- Each unit can be mounted in reverse position.
- Equipped with a Extra-High setting.
- Can incorporate a medium-performance filter (optional, installed at site).

Performance

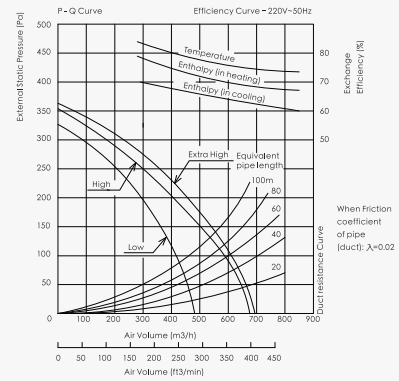

Dimensions & Parts Name

Unit: mm

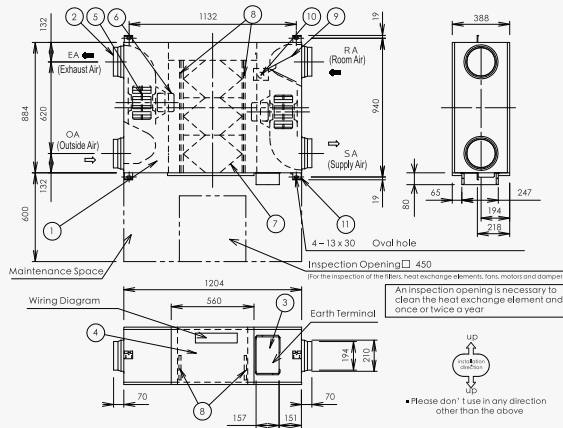

No.	Parts Name	Qty.
1	Frame	1
2	Adapter	4
3	Electrical Equipment Box	1
4	Inspection Cover	1
5	Fan	2
6	Motor	2
7	Heat Exchange Element	3
8	Filter	2
9	Damper	1
10	Damper Motor	1
11	Ceiling Suspension Fixture	4

Remarks:

- Duct Size (Nominal Diameter): Ø200
- The dimensions do not include the thickness of the insulation material in the unit

Specification

Power Source	Notch	Frequency	Ventilation Mode	Input [W]	Current [A]	Air Volume [m³/h]	External Static Pressure [Pa]	Temperature Exchange Efficiency (%)	Enthalpy Exchange Efficiency (%)		Noise [dB]	Product Weight [kg]
									Cooling	Heating		
220 - 240V	Extra High	50	Heat Exchange Ventilation	326-347	1.45-1.48	650	65	75	62	68	36.5-37.5	68
			Normal Ventilation	326-347	1.45-1.48	650	65	-	-	-	36.5-37.5	
	High	50	Heat Exchange Ventilation	269-295	1.22-1.23	650	40	75	62	68	34.5-35.5	
			Normal Ventilation	269-295	1.22-1.23	650	40	-	-	-	35.0-35.5	
	Low	50	Heat Exchange Ventilation	200-210	0.88-0.91	460	40	79	66	73	30.0-32.0	
			Normal Ventilation	200-210	0.88-0.91	460	40	-	-	-	30.0-32.0	

* This noise of the product is the value which was measured at the acoustic room. Actually, in the established condition, that undergo influence by the echoing of the room and so that become bigger than the display numerical value. The input, current and exchange efficiency are values at the time of mentioned air volume. The noise level shall be measured 1.5m below the center of the unit. The temperature exchange efficiency averages that of when cooling and when heating.

FY-800ZDY8



Features

- Counter-flow heat-exchange element used for reduced noise and more compact and slim body shape.
- All maintenance can be performed through a single inspection hole.
- Straight air supply/exhaust system used for easier installation.
- Each unit can be mounted in reverse position.
- Equipped with a Extra-High setting.
- Can incorporate a medium-performance filter (optional, installed at site).

Performance

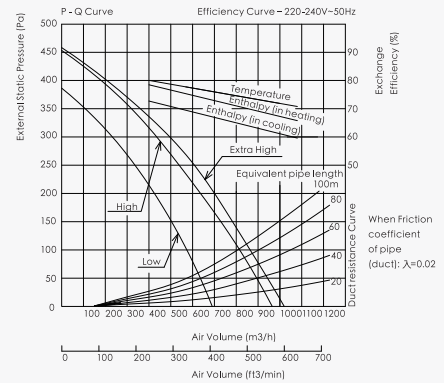

Dimensions & Parts Name

Unit: mm

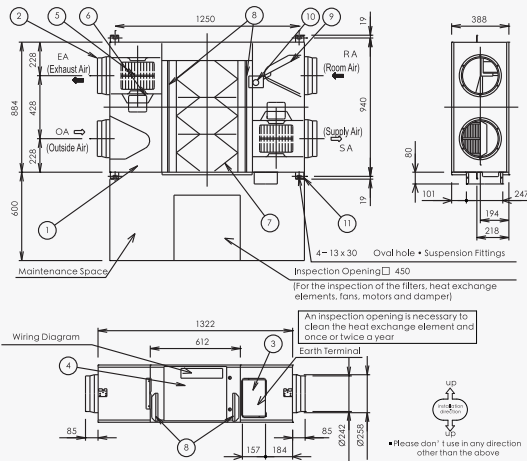

No.	Parts Name	Qty.
1	Frame	1
2	Adapter	4
3	Electrical Equipment Box	1
4	Inspection Cover	1
5	Fan	2
6	Motor	2
7	Heat Exchange Element	3
8	Filter	2
9	Damper	1
10	Damper Motor	1
11	Ceiling Suspension Fixture	4

Remarks:
 ■ Duct Size (Nominal Diameter): Ø250
 ■ The dimensions do not include the thickness of the insulation material in the unit

Specification

Power Source	Notch	Frequency	Ventilation Mode	Input [W]	Current [A]	Air Volume [m³/h]	External Static Pressure [Pa]	Temperature Exchange Efficiency (%)	Enthalpy Exchange Efficiency (%)		Noise [dB]	Product Weight [kg]
									Cooling	Heating		
220 - 240V	Extra High	50	Heat Exchange Ventilation	387-418	1.74-1.76	800	140	75	65	71	37.0-37.5	71
			Normal Ventilation	387-418	1.74-1.76	800	140	-	-	-	37.0-37.5	
	High	50	Heat Exchange Ventilation	360-378	1.58-1.64	800	110	75	65	71	36.5-37.0	
			Normal Ventilation	360-378	1.58-1.64	800	110	-	-	-	36.5-37.0	
	Low	50	Heat Exchange Ventilation	293-295	1.23-1.33	630	55	76	68	74	33.5-34.5	
			Normal Ventilation	293-295	1.23-1.33	630	55	-	-	-	33.5-34.5	

* This noise of the product is the value which was measured at the acoustic room. Actually, in the established condition, that undergo influence by the echoing of the room and so that become bigger than the display numerical value. The input, current and exchange efficiency are values at the time of mentioned air volume. The noise level shall be measured 1.5m below the center of the unit. The temperature exchange efficiency averages that of when cooling and when heating.

ENERGY RECOVERY VENTILATORS

FY-01KZDY8A



Features

- Counter-flow heat-exchange element used for reduced noise and more compact and slim body shape.
- All maintenance can be performed through a single inspection hole.
- Straight air supply/exhaust system used for easier installation.
- Each unit can be mounted in reverse position.
- Equipped with a Extra-High setting.
- Can incorporate a medium-performance filter (optional, installed at site).

Performance

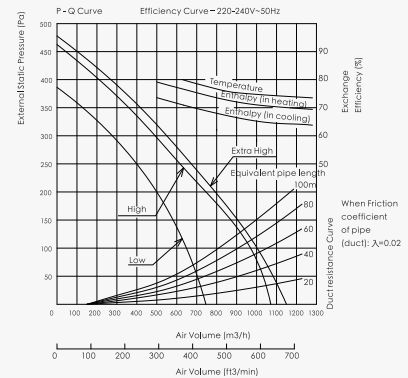

Dimensions & Parts Name

Unit: mm

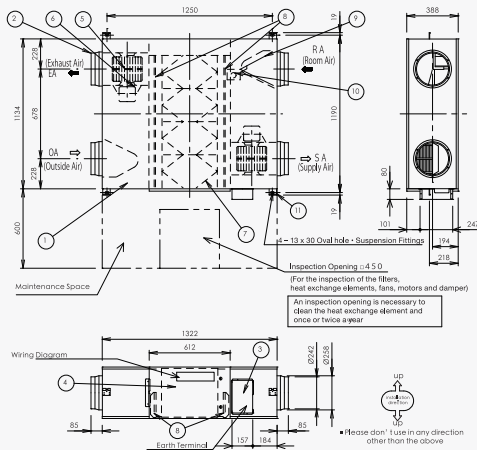

No.	Parts Name	Qty.
1	Frame	1
2	Adapter	4
3	Electrical Equipment Box	1
4	Inspection Cover	1
5	Fan	2
6	Motor	2
7	Heat Exchange Element	4
8	Filter	2
9	Damper	1
10	Damper Motor	1
11	Ceiling Suspension Fixture	4

Remarks:

- Duct Size (Nominal Diameter): Ø250
- The dimensions do not include the thickness of the insulation material in the unit

Specification

Power Source	Notch	Frequency	Ventilation Mode	Input [W]	Current [A]	Air Volume [m³/h]	External Static Pressure [Pa]	Temperature Exchange Efficiency (%)	Enthalpy Exchange Efficiency (%)		Noise [dB]	Product Weight [kg]
									Cooling	Heating		
220 - 240V	Extra High	50	Heat Exchange Ventilation	437-464	1.93-1.99	1000	105	75	65	71	37.5-38.5	83
			Normal Ventilation	437-464	1.93-1.99	1000	105	-	-	-	39.5-40.5	
	High	50	Heat Exchange Ventilation	416-432	1.80-1.89	1000	80	75	65	71	37.0-37.5	
			Normal Ventilation	416-432	1.80-1.89	1000	80	-	-	-	39.0-39.5	
	Low	50	Heat Exchange Ventilation	301-311	1.29-1.37	700	75	79	70	76	33.5-34.5	
			Normal Ventilation	301-311	1.29-1.37	700	75	-	-	-	35.5-36.5	

* This noise of the product is the value which was measured at the acoustic room. Actually, in the established condition, that undergo influence by the echoing of the room and so that become bigger than the display numerical value. The input, current and exchange efficiency are values at the time of mentioned air volume. The noise level shall be measured 1.5m below the center of the unit. The temperature exchange efficiency averages that of when cooling and when heating.

FY-EB90S1



Features

Power : 220-240V / 50Hz

Rated Wattage : 3.4W

Weight : 0.3kg

Outer Size : 116mm x 120mm x 40mm

Dimensions

Unit: mm

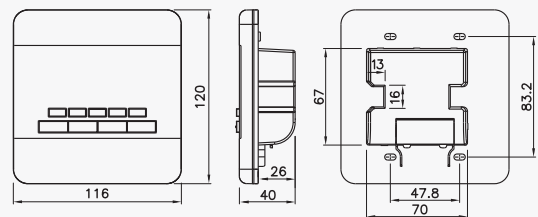

General Information

All ERV Models

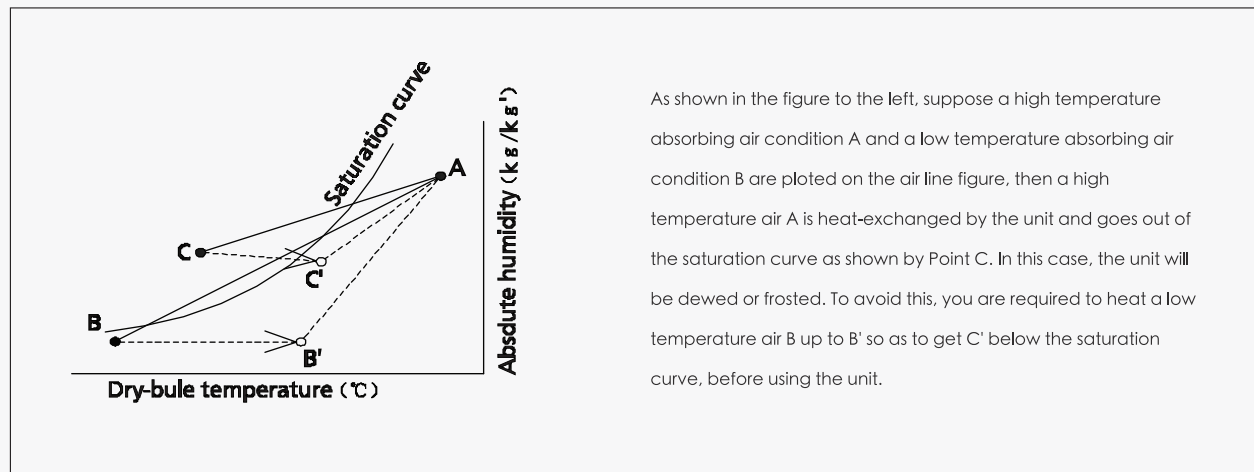

Outdoor air range - Temperature range -10°C~40°C
Relative humidity 85% or less

Indoor air range - Temperature range -10°C~40°C
Relative humidity 85% or less

Installation requirements

Same as the indoor air conditions

* Indoor air here means air in air-conditioned living rooms. Its use in refrigerators or other places where temperature can fluctuate greatly is prohibited even if a temperature range is acceptable.

Example Indoor air conditions

During cooling period - Temperature 27°C
Relative humidity 50%

During heating period - Temperature 20°C
Relative humidity 40%

Panasonic[®]

Panasonic Ecology Systems Co., Ltd.
<http://www.plshk.panasonic.hk/>

- Specifications are subject to change without prior notice
- Actual colors may vary slightly from shown.

CATALOG NO: P-MYERV001
Printed in Hong Kong 04.20